

\*\*\*RIGHT HAND SHOWN, LEFT HAND OPPOSITE\*\*\*

MATERIAL LIST			
ITM	DESCRIPTION	LENGTH	QTY
1	Angle-S 2.36 x 2.36x 0.25	23.75	1
2	Bar-Rect-SC 2.36x 0.25	19.9	1
3	Angle-S 2.36x 2.36x 0.25	17.75	1

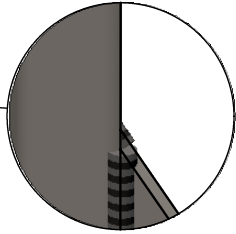

DETAIL C  
SCALE 1 : 3

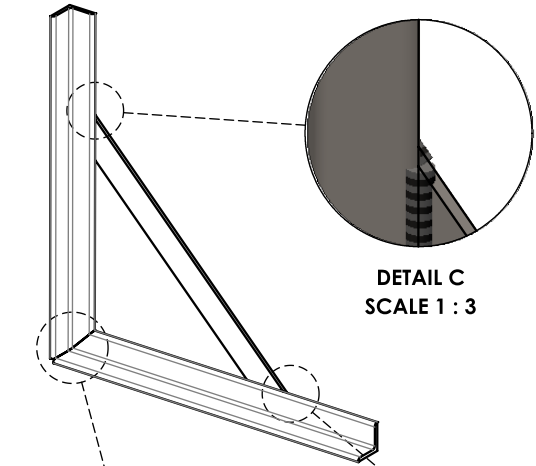
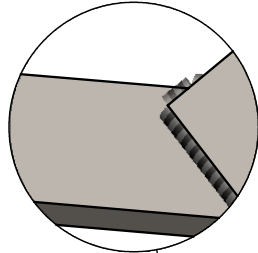

DETAIL E  
SCALE 1 : 3

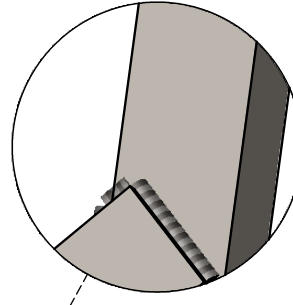

DETAIL D  
SCALE 1 : 3

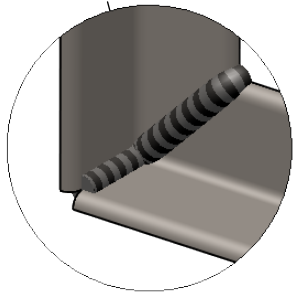

DETAIL B  
SCALE 1 : 3

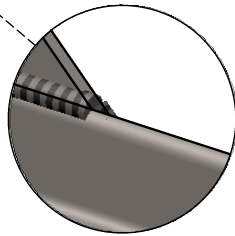

DETAIL A  
SCALE 1 : 3

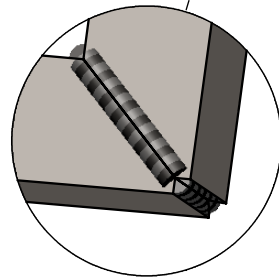
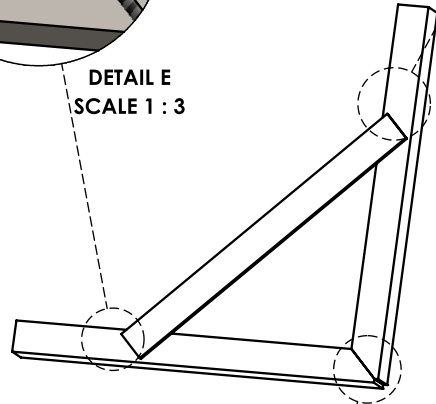

DETAIL F  
SCALE 1 : 3

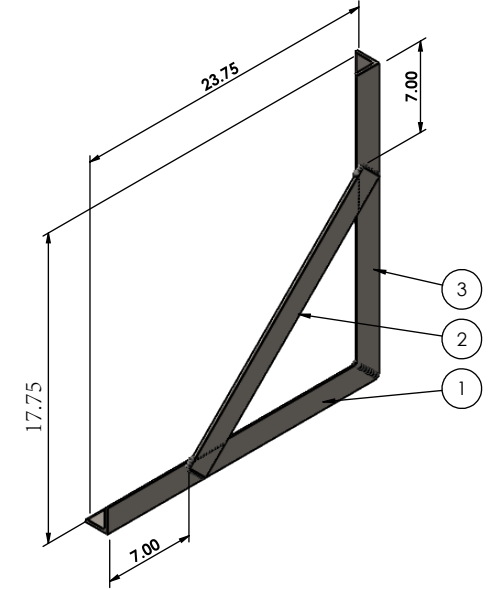

**NOTE 1:**

- IF DEPTH OR HEIGHT OF BRACKET IS 18IN. OR LESS, DISTANCE BETWEEN END OF ANGLE AND CORNER OF FLATBAR IS PERMITTED TO BE 1IN.

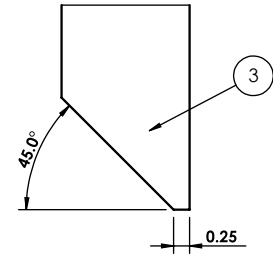
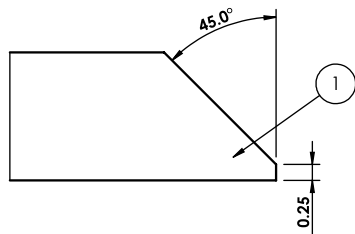

REVISIONS		
REV.	DESCRIPTION	DATE
B	ADDED REVISION TABLE, CHANGED FLATBAR PLACEMENT AND LENGTH AND UPDATED SHEET FORMAT	09/05/2016
C	CORRECTED MIS-LABELED MATERIAL REFERENCE IN DESCRIPTION	6/14/2016

PartNo: 118-001 **REV-C**

Material: **ASTM A36 Steel**

Descr: 24D" x 18H" Regular steel toolbox bracket RH

Client: \_\_\_\_\_ Date: **10/18/2018**

Drawn By: \_\_\_\_\_ Sheet Size: 8.268in\*11.693in Weight(lb): \_\_\_\_\_ Scale: 1:12 SHEET 1 OF 1

Dimensions are in inches unless otherwise specified